**ZXDSL 831A II
User's Manual**

Document version: 201004012-R3.1

Copyright 2006 ZTE Corporation

All rights reserved.

No part of this documentation may be excerpted, reproduced, translated, annotated or duplicated, in any form or by any means without the prior written permission of ZTE Corporation.

ZTE CORPORATION reserves the right to modify this manual for product upgrade or other causes without notifying users in advance.

Limited warranty

ZTE warrants that, for one year from the date of delivery by ZTE to purchaser's designated carrier, the Equipment will remain free from defects in design, material and workmanship under normal use and service and will conform in all material respects to the applicable specifications set forth in purchase order or agreement; ZTE does not warrant that operation of the Equipment will be error-free or uninterrupted.

In accordance with ZTE's standard, warranty terms, ZTE shall, at its option, repair or replace any defective or nonconforming item, provided that (a) purchaser/End User gives ZTE written notice of the defect or nonconformity within the warranty period specified above promptly after Reseller is notified by the End User of the same; and (b) End User returns the defective item at its expense to ZTE's nominated Customer Service Department in accordance with ZTE's standard parts exchange procedures.

This warranty does not apply to defects or errors in the Equipment caused by:(a) reasonable abrasion of equipments; (b)End User's failure to follow ZTE's installation, operation or maintenance instructions or procedures; (c) End User's mishandling, misuse, negligence, or improper installation, uninstall, storage, servicing or operation of the Equipment; (d) modifications or repairs not made by ZTE or a ZTE-certified individual;(e) power failures, surges, fire, flood, accident, actions of third parties or other events outside ZTE's reasonable control. (f) usage of products of third Parties, or usage conjunction with third parties provided that such defects is due to the conjunction;(g) any

other cause beyond the range of normal usage for equipments. End User shall assure that Equipment is installed and maintained by ZTE or ZTE-certified individuals in accordance with ZTE's certification procedures; provided that if End User causes or permits services to be provided by individuals who are not ZTE-certified, the Warranty shall be void as to all Equipment serviced in breach of this sentence. End User shall have no right to reject, return, or receive a refund for any Equipment from ZTE. Any item repaired or replaced by ZTE shall continue to be warranted for longer of the remainder of the original warranty period or 90 days from the date the repaired or replaced part is delivered to the carrier.

THIS WARRANTY (1) IS END USER'S SOLE REMEDY AND ZTE'S SOLE LIABILITY FOR DEFECTIVE OR NONCONFORMING ITEMS , AND IS IN LIEU OF ALL OTHER WARRANTIES, EXPRESSED, IMPLIED OR STATUTORY, INCLUDING BUT NOT LIMITED TO THE IMPLIED WARRANTIES OF MERCHANTABILITY AND FITNESS FOR A PARTICULAR PURPOSE, UNLESS OTHERWISE REQUIRED UNDER THE MANDATORY PROVISIONS OF THE CHINESE LAW, AND (2) IS BETWEEN ZTE AND END USER (AS THE ORIGINAL PURCHASER FOR END USE) AND MAY NOT BE TRANSFERRED OR ASSIGNED, BY OPERATION OF LAW OR OTHERWISE, WITHOUT ZTE'S PRIOR WRITTEN CONSENT.

Limitation of Liability

ZTE SHALL NOT BE LIABLE FOR ANY LOSS OF PROFITS OR INDIRECT, SPECIAL, INCIDENTAL OR CONSEQUENTIAL DAMAGES RESULTING FROM OR ARISING OUT OF OR IN CONNECTION

WITH USING OF THIS PRODUCT, WHETHER OR NOT ZTE HAD BEEN ADVISED, KNEW OR SHOULD HAVE KNOWN OF THE POSSIBILITY OF SUCH DAMAGES, INCLUDING, BUT NOT LIMITED TO, LOST PROFITS, COST OF CAPITAL, COST OF SUBSTITUTE FACILITIES OR EQUIPMENT, ANY DOWNTIME COSTS OR CLAIMS OF END USERS. THE LIABILITY OF EACH PARTY UNDER THIS AGREEMENT, WHETHER ARISING OUT OF BREACH OF CONTRACT (INCLUDING BUT NOT LIMITED TO BREACH OF WARRANTY) OR TORT (INCLUDING BUT NOT LIMITED TO NEGLIGENCE AND STRICT LIABILITY) OR UNDER AN INDEMNIFICATION PROVISION SHALL IN NO EVENT EXCEED THE AGGREGATE AMOUNT BENEFITED BY ZTE IN THE PRODUCTS FROM WHICH SUCH LOSS OR DAMAGE DIRECTLY AROSE.

Confidentiality

End User agrees that End User will receive confidential or proprietary information ("Confidential Information") in connection with the purchase and deployment of ZTE Equipment. End User will not disclose ZTE's Confidential Information, will use it only for purposes for which it was disclosed, and must treat it with the same degree of care as it does its own similar information, but with no less than reasonable care. End User agrees that the terms herein, the Equipment and all ZTE documentation is ZTE Confidential Information.

Contents

Chapter 1 Safety Guidance.....	1
1.1 Safety Check.....	1
1.2 Safety Cautions.....	1
Chapter 2 Overview	3
2.1 Features.....	3
2.2 Product Specifications	4
2.3 Package Check.....	4
2.4 System Requirement.....	5
Chapter 3 Installation Preparation.....	6
3.1 Hardware Description.....	6
3.2 Hardware Connection	7
Chapter 4 Install USB Driver	13
4.1 USB Driver Installation	13
4.2 USB Driver Uninstall	19
Appendix A FAQs	22
Appendix B Standard Compliance.....	25

Chapter 1 Safety Guidance

1.1 Safety Check

Before installing the ZXDSL 831A II ADSL equipment, you must check the following items.

1 Electric safety

- Ensure that there are no inflammable, conductive or moist objects around. Check whether the cables are aged and whether other electrical appliances are placed stably.

2 Equipment position

- Because the running electric devices easily generate heat, please ensure that these devices are positioned in a well ventilated environment.
- The devices should be placed on a stable and flat plane.
- Never expose the equipment to direct sunshine, and never place it on a PC case.
- Keep the equipment away from heat and water.
- Check whether power supply is available. The input voltage fluctuation range must be less than 10%. The power plug should not share one socket with a hair drier, iron or refrigerator.

1.2 Safety Cautions

- Read the user manual carefully before using the equipment.
- Note all Cautions in the user manual and product guide.
- Never use an accessory unbelonging to the equipment without prior consent of the manufacture, because it may cause fire or product damage.

- Use the power adapter accompanied in the package.
- Rather than directly connecting phones to the ADSL line, led them out from the phone interface of the splitter.
- Never place any objects on the equipment.
- Keep the equipment dry, ventilated and rainproof, and clean.
- Unplug the power and all connection cables in case of thunderstorms, to protect the equipment against lightning.
- Clean the equipment using a soft and dry cloth rather than liquid or atomizers. Power off the equipment before cleansing it.
- Power off the idle equipment.
- Keep the ventilation hole clean and prevent any objects from dropping into the equipment through it. Otherwise, it may cause short circuit and further cause equipment damage and fire. Do not spray liquid on the surface of the equipment.
- Do not open the case of the equipment, especially during equipment power-on.
- Before plugging/unplugging the power, make sure that the power is off, thus avoiding surge.
- Be careful when unplugging the power, because the transformer may be very hot.
- Keep the equipment and all its parts and accessories out of children's reach.

**Note:**

Please read the above safety guidance carefully before equipment use. Users should assume responsibilities for any accidents due to non-compliance with the above instructions.

Chapter 2 Overview

The ZXDSL 831A II is an ADSL access device that allows multiple line transmission modes. The equipment provides a 10/100Base-T Ethernet interface and a USB port in a local LAN device. Through the high-speed ADSL access service, the ZXDSL 831A II can provide the broadband Internet service or enterprise network access service for users.

2.1 Features

The ZXDSL 831A II, as an routing-capable ADSL MODEM, is of the following characteristics:

- Providing ADSL high-speed Internet access via a common telephone cable
- Supporting multiple line modes (self-adaptive lines)
- Providing a 10/100Base-T Ethernet interface
- Providing a USB1.1 interface
- More highly reliable, simpler operation and less power consumption
- Supporting the Bridge or Router mode
- Supporting the built-in PPPoE dialup function
- Supporting the Network Address Translation (NAT) function
- Supporting the DHCP server function
- Supporting the UPnP function
- Supporting the Quick configuration function
- Backup the configuration files to a local computer or upload the saved configuration files to the ZXDSL 831A II.

2.2 Product Specifications

- Environmental requirements

Environmental temperature: 0°C-40°C (32 °F-104°F)

Humidity: 20% - 90% (non-condensing)

- Power specification

Power adapter: Input: AC 100-240V ±10%, 50 Hz

Output: DC 12V, 500mA

- Certification

CE



Note:

In some countries or regions, a DC power adapter may be used instead of an AC power adapter in accordance with customers' request.

2.3 Package Check

- ZXDSL 831A II ADSL MODEM ×1
- Splitter ×1
- Power Adapter ×1
- RJ-11 telephone cable ×2
- RJ-45 Ethernet cable ×1
- USB cable ×1
- User's Manual ×1

-
- Quality Warranty Card ×1
 - Certificate of Quality ×1
 - CD ×1

Note: for your information only, please refer to the actual product.



Note:

Please use a power adapter that matches the ZXDSL 831A II package.

2.4 System Requirement

Before installing the ZXDSL 831A II, please check the following items.

1 ADSL Services Subscription

If you have subscribed for the ADSL service, your ADSL operator must provide at least one valid IP address for you (static allocation or dialup dynamic allocation).

2 Computer configuration

Please make sure that the system has been equipped with the 10M/100M Ethernet adapter and supports the TCP/IP protocol.

Because ADSL can be used for broadband access and involves a wide range of multimedia services, you are recommended use a computer with such configurations as: above PentiumIII, 64 M memory, 10 G hard disk, graphic accelerating adapter with above 2 M display memory, audio adapter and sound box.

3 Operating system

Operating systems can be Windows 98SE, Windows Me, Windows 2000 or Windows XP. For system configuration in the WEB interface, the browser of Internet Explorer V 6.0 or later.

Chapter 3 Installation Preparation

3.1 Hardware Description

Front panel

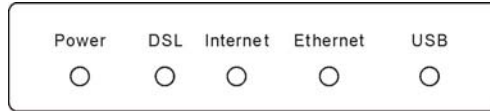

Figure 3.1-1 Front Panel of the ZXDSL 831A II

Table 3.1-1 Descriptions of the LEDs on the Front Panel

LED No.	Color	Status	Note
Power	Green/Red	Off	Power off
		Red Flash	Power on self-test or software upgrade
		Green On	Power is on and the device operates normally
DSL	Green	Off	No signals are detected
		Flash	The MODEM is trying to be in the activation status
		On	The MODEM has been activated.
Internet	Green/Red	Off	The system is under the Bridge mode or the ADSL has not been connected
		Green Flash	There are some data packets passing the MODEM
		Green On	The system is under the Route mode and the ADSL has been connected. The MODEM IP data packet can be normally transferred (For example, the built-in PPPOE has been established and the dynamic IP address has been obtained).
		Red On	Device attempted to become IP connected and failed (no DHCP response, no PPPoE response, PPPoE authentication failed, etc.)
USB	Green	Off	The USB interface is in the non-communication status
		Flash	Data is received or sent on the USB interface

LED No.	Color	Status	Note
Ethernet	Green	On	The USB interface is in the communication status
		Off	The Ethernet interface is in the non-communication status
		Flash	Data is received or sent on the Ethernet interface
		On	The Ethernet interface is in the communication status

Rear panel

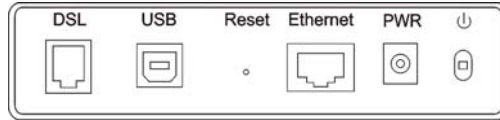

Figure 3.1-2 Rear Panel of the ZXDSL 831A II

Table 3.1-2 Description of Interfaces on the Rear Panel

Item	Introduction
DSL	RJ-11 connection interface: The equipment is connected to the ADSL line or splitter via the telephone line.
USB	USB connection interface: Connect it to the PC computer using the USB cable.
Reset	In the power-on state, you can restore the system to the default configuration by using a thin needle to press this slot for five seconds
Ethernet	RJ-45 connection interface: Connect it to the PC computer or other network devices using the network cable.
PWR	Power interface. Connect it to the power adapter.
	Power switch

3.2 Hardware Connection

Connection 1

The following connection method is recommended.

Figure 3.2-1 shows the connection between a ZXDSL 831A II, computer, splitter and telephones.

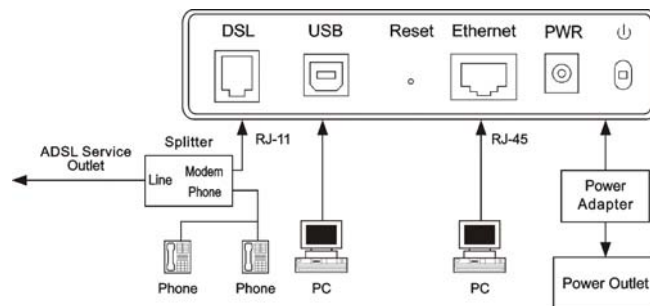

Figure 3.2-1 ZXDSL 831A II Connection Schematic Diagram (No Phone sets are Installed Before the Splitter)

Connection 2

Figure 3.2-2 shows the connection when the splitter is installed near the ZXDSL 831A II.

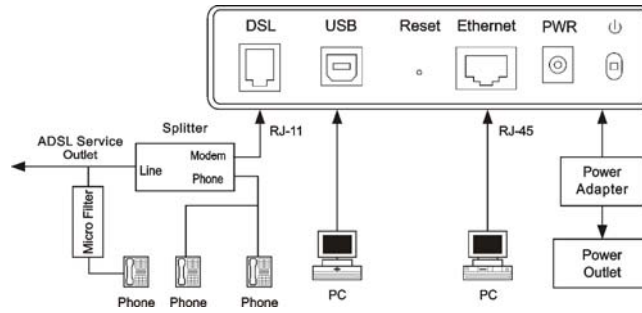

Figure 3.2-2 ZXDSL 831A II Connection Schematic Diagram (Phone sets are Installed Before the Splitter)



Note:

In the circumstance where the first connection example is not applicable and you choose to use the second example, you must install a MicroFilter on the telephone cable (as illustrated in Figure 3.3-2, do not use a splitter to replace the MicroFilter).

Installing a telephone directly before the splitter will lead to a failure of connection between the ZXDSL 831A II and the device at central office side, or a failure of access into the Internet, or a slow connection speed. If you really need to add a telephone set before the splitter, you have to add a MicroFilter before the telephone set. Do not connect several telephones before the splitter. Moreover, do not connect several telephones with MicroFilters.

The filter is not a standard-configuration device and you should separately purchase it from the operator.

Connection procedures

- 1 Power off the equipment before all the other devices are connected.
- 2 Connect the network cables: Insert the RJ-45 Ethernet cable connector into the Ethernet interface of the ZXDSL 831A II, and connect its other

terminal to the Ethernet adapter of the customer computers or ports of other network devices.

3 Connect the plug of the USB cable into the USB port of the ZXDSL 831A II, connect the other end of the USB cable to the USB port of the PC.

4 Connect the splitter

The splitter has three interfaces, which are described as follows:

- LINE: Connect the user telephone cable (RJ11 interface).
- MODEM (or ADSL): Connect the DSL interface of the ZXDSL 831A II.
- PHONE (or TEL): Connect the phone sets.

The installation process is as follows: Connect the DSL interface of the ZXDSL 831A II to the MODEM interface of the splitter using the RJ-11 telephone cable, connect the phone set lines to the PHONE interface of the splitter, and then connect the user telephone cable port to the LINE interface of the splitter.

5 Connect the power

Connect one terminal of the power adapter to the PWR interface of the ZXDSL 831A II, and the other terminal to the socket on the wall, and then switch on the power of the ZXDSL 831A II equipment.

Checking all connection cables

Check all connection cables following the below procedure.

1 Check the ADSL cable connection

If the DSL LED is on upon power-on of the ZXDSL 831A II, it indicates that the ADSL line is correctly connected (Generally it takes one to two minutes to perform the ADSL connection).

2 Check the computer connection

If both the LINK LED on the computer adapter and the Ethernet LED of the ZXDSL 831A II turn green, it indicates that the computer and the ZXDSL 831A II equipment are correctly connected.

3 Check the telephone cable connection

The telephone cable is correctly connected if the received telephone signals are normal and free of noise. And the telephone will not be affected no matter whether the ZXDSL 831A II is powered on or off.

Chapter 4 Install USB Driver

If you want the ZXDSL 831A II to be connected with a PC through the USB interface, you need to install the USB driver first. Read a certain section below pertinent to your operating system. If you have already installed the driver, skip this chapter.

ZXDSL 831A II is a device with both Ethernet Interface and USB Interface, which is independent, you may use either of them to connect to the different computers, in this way the two computers can connect to the network at one time. ZXDSL 831A II can be seen as a simple two-port HUB. So, do not connect both the Ethernet Interface and USB Interface to a same computer.

When using USB Interface, you must install the drivers. After installation, a virtual network card, "ZTE USB Remote NDIS Device", will be added into the computer. It has all the functions of a real network card, and it makes installation more easily

NOTES:

The following shows the steps for Windows®XP, the installation, configuration and uninstall of Windows®98 or Windows®2000 are similar to this.

4.1 USB Driver Installation



Descriptions

Install the driver following the system indication. Do not plug the USB cable until the indication interface pops up (Fig. 4.1-1 for Windows XP). Otherwise, the driver may not be installed or uninstalled properly.

For Windows XP

The steps are as follows:

- 1 Connect USB port of the ZXDSL 831A II to USB port on your PC with the USB cable that comes with the ZXDSL 831A II.
- 2 plug in the power cord, and turn on the power.
- 3 Once the new hardware is detected as shown in the dialog box below, Choose "No, not this time". As shown in Figure 4.1-1, Click "Next" button.



Figure 4.1-1

- 4 The dialog box is as shown in Figure 4.1-2, Choose "Install from a list or specific location(Advance)", and Click "Next" button.

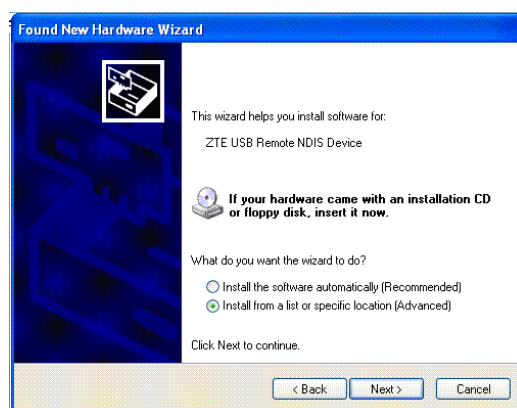

Figure 4.1-2

- 5 The dialog box is as shown in Figure 4.1-3. Choose "Search for the best driver in these locations", and Click "Next" button.

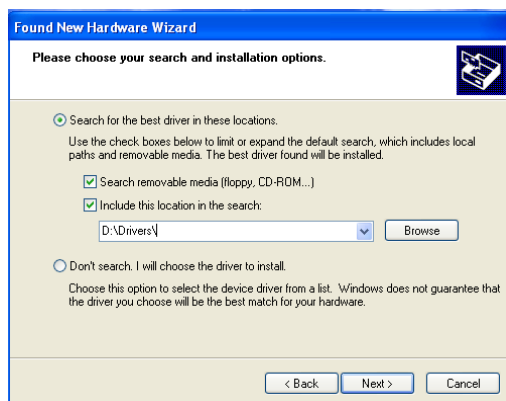

Figure 4.1-3

6 A new box will pop up for selection of the location of the driver. If the location is incorrect please click "Browse" and select the right location, then click "Next" button. As shown in Figure 4.1-4.

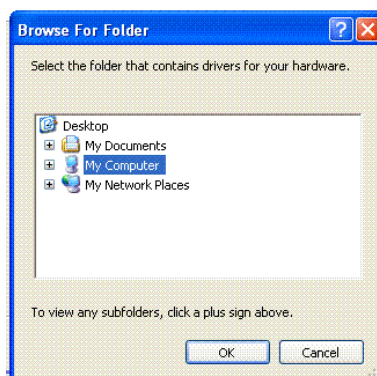

Figure 4.1-4

7 Click "Continue Anyway" for any dialog box pops up.

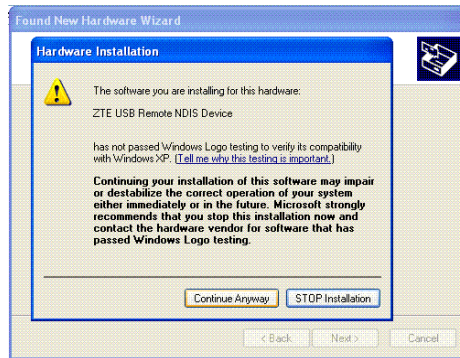

Figure 4.1-5

8 A message box will show the installation of "ZTE USB Remote NDIS Device" is complete. Click "Finish" button. As shown in Figure 4.1-6.



Figure 4.1-6

9 After the steps above, you will find there is a new item called "ZTE USB Remote NDIS Device" in "Control Panel"->"System"->"Hardware"->"Device Manager"->"Network adapters". As shown in Figure 4.1-7. And a new "Local

"Area Connection X" is added in "Network Connections". As shown in Figure 4.1-8.

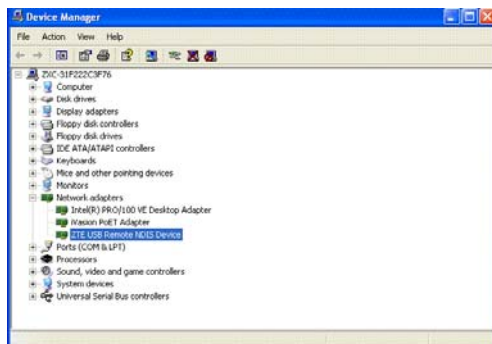

Figure 4.1-7

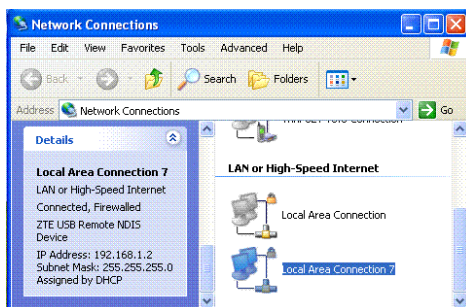

Figure 4.1-8



Note:

If the USB device cannot be detected by the system, check the USB cable between the PC and the device, and make sure that the device is powered on.

4.2 USB Driver Uninstall

For Windows XP

- 1 Right click the icon of "My Computer" on the desktop, choose "Properties" item on menu pop up. As shown in Figure 4.2-1.



Figure 4.2-1

- 2 Click "Device Manager" button in "Hardware" page. As shown in Figure 4.2-2.

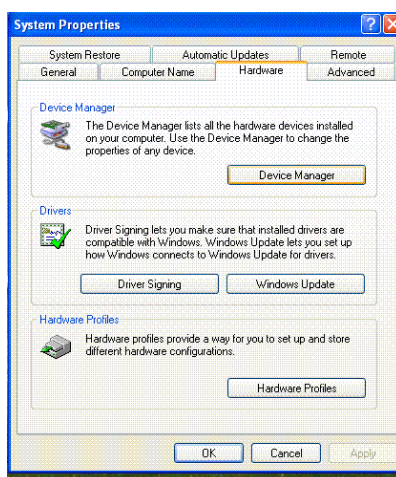

Figure 4.2-2

- 3 Double Click the "ZTE USB Remote NDIS Device" in "Device Manager" dialog box. As shown in Figure 4.2-3

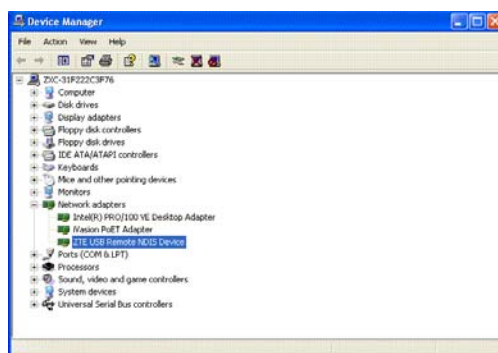

Figure 4.2-3

- Click "Uninstall" button in "Driver" page. As shown in Figure 4.2-4.

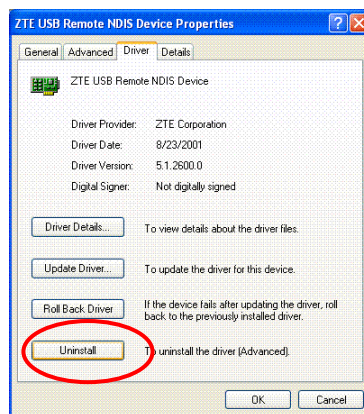

Figure 4.2-4

- Click "OK" when the dialog box shown as below to finish the uninstall.



Figure 4.2-5

Appendix A FAQs

1	<p>All indicators are off after the ZXDSL 831A II equipment is powered on</p> <p>First make sure that you have inserted the power adapter of the ZXDSL 831A II into a working power socket and that the ZXDSL 831A II has been powered on (the switch button is pressed down). If the indicators are still off after confirmation of the above items, the hardware is damaged probably. You may contact local operators for maintenance. Never dismantle the equipment by yourself.</p>
2	<p>Will ADSL affect the telephone conversation quality? Will making phone calls cause a slow online rate?</p> <p>ADSL separates voices from data through the frequency division multiplexing technology. Therefore, voices and data run in different paths without mutual interference. Neither the access rate nor conversation quality will fall even if you are in a call and on line simultaneously.</p>
3	<p>How to properly install telephone extensions or other devices on the ADSL line?</p> <p>It is recommended to first connect the ADSL splitter to the incoming customer end of the telephone cable, and then connect the phone sets to the splitter interfaces. Installing a telephone directly before the splitter will lead to a failure of connection between the ZXDSL 831A II and the device at central office side, or a failure of access into the Internet, or a slow connection speed. Connecting some other electronic devices between the incoming customer end and splitter may affect the ADSL communications (since ADSL has a higher requirement for the line quality) and furthermore affect the normal operation of ADSL. If the phone sets are required to be connected before the splitter, you should serially connect the filter MicroFilter before the phone sets (Generally, to minimize interference, only one filter MicroFilter can be hang before the splitter).</p>
4	<p>Sometimes, the ADSL users cannot gain access to the Internet normally</p> <p>First check whether the ZXDSL 831A II is in the normal state (Check the indicators with this user manual). If yes, the computer or application network may be faulty, which is unrelated with ADSL. If the ADSL MODEM is abnormal, check the status of indicators one by one to remove the fault.</p> <p>You are suggested to first make sure the following items before seeking help from operators: 1. The ADSL telephone cable connectors are proper; 2. The ADSL is away from the power cable and large-power electronic devices; 3. No telephone extensions and fax machines are installed between the ADSL incoming line and splitter; 4. The splitter has been correctly installed; 5. The ADSL MODEM is of good heat dissipation.</p>

5	Password verification failure
	<p>MODEM synchronization and connection are normal. However, sometimes the password fails to be verified.</p> <ol style="list-style-type: none"> 1. Note that the account and password are case sensitive and some accounts contain a domain name. 2. Virtual dialup software. It is possible that sometimes the virtual dialup software is faulty, or conflict with other software in the operating system. At this time, you are suggested to reinstall the dialup software or replace it with other software. 3. Network adapter drive program problem. 4. In arrears of fees. Pay the fee timely in this case.
6	What are reasons for ADSL synchronization failure (also referred to link down or link establishment failure)?
	<p>If the ADSL suddenly fails to be synchronized (link down) during application, usually the DSL indicator of the MODEM will not be solid on. You are suggested for checkup in the following sequence:</p> <ol style="list-style-type: none"> 1. First check the quality of incoming cables and incoming cable connectors. 2. Install the ADSL Modem correctly based on the user guide, to minimize the number of taps. 3. Check whether the telephone cables and ADSL are in good contact or whether the telephone cables are normal. 4. Try to disconnect the splitter and directly connect the ADSL Modem to the incoming customer cable end to ensure that the problem is not due to improper installation or incoming customer line quality. If the ADSL can be synchronized again, it means that installation of the incoming customer part is improper. Please reinstall it according to the user guide. 5. If the ADSL still fails to be synchronized after the ADSL Modem has been connected to the incoming customer cable end, contact the operators to check whether it is due to external line failure or Modem failure. 6. If the splitter problem is determined, call the operators for maintenance or replacement. 7. The problem may be also due to the end office equipment fault of the operator. Call the operator to confirm it. 8. Too long connection cable between the splitter and ADSL Modem may cause poor anti-interference performance and synchronization difficulty. Therefore, the connection cable should not be too long.

7	The authenticated user names and passwords cannot be re-authenticated?
	<p>This problem may be due to the following reasons:</p> <ol style="list-style-type: none">1. Your account has expired or you are a defaulting subscriber (please pay the deficit sum).2. You move into a new area. Because the account and the path PVC are bundled by some operators, your previous account and password cannot be authenticated after you changed your path.3. One of your accounts has logged on successfully. Therefore, you will fail to be re-authenticated because the operator has recognized the uniqueness of this account4. Maybe you failed to deregister your account timely in the Broadband Access Server (BAS) when you were off line abnormally, so the BAS or the billing system deemed that your account was still available. Therefore, your re-login may fail because of uniqueness of your account You are suggested to redial up later. If still failing, contact the operator for a solution.

Appendix B Standard Compliance

The equipment complies with the following ADSL standards:

Standard	Note
ANSI T1.413 Issue 2	
ITU G.992.1 Annex A	
ITU G.992.2 Annex A	
ITU G.992.3 Annex A	Only supported by the ZXDSL 831A II
ITU G.992.3 Annex L	Only supported by the ZXDSL 831A II
ITU G.992.5 Annex A	Only supported by the ZXDSL 831A II
ITU G.994.1	

ZTE's equipment complies with the following national standards of the PRC:

Standard No.	Standard Name
GB 4943-2001	Safety of Information Technology Equipment
GB 9254-1998	Information Technology Equipment – Radio Disturbance Characteristics–Limits and Methods of Measurement
GB/T 17618-1998	Information Technology Equipment–Immunity Characteristics–Limits and Methods of Measurement
GB 17625.1-2003	Electromagnetic Compatibility Limit and Harmonic Current Emission Limit (input current of each phase of equipment ≤ 16 A)
GB 17625.2-1999	Electromagnetic Compatibility Limits – Limitation of Voltage Fluctuations and Flicker in Low-voltage Supply Systems for Equipment with Rated Current ≤ 16 A

This device complies with Part 15 of the FCC Rules. Operation is subject to the following two conditions:

- (1) this device may not cause harmful interference, and
- (2) this device must accept any interference received, including interference that may cause undesired operation.

Changes or modifications not expressly approved by the party responsible for compliance could void the user's authority to operate the equipment.

This equipment has been tested and found to comply with the limits for a Class B digital device, pursuant to part 15 of the FCC Rules. These limits are designed to provide reasonable protection against harmful interference in a residential installation. This equipment generates, uses and can radiate radio frequency energy and, if not installed and used in accordance with the instructions, may cause harmful interference to radio communications. However, there is no guarantee that interference will not occur in a particular installation. If this equipment does cause harmful interference to radio or television reception, which can be determined by turning the equipment off and on, the user is encouraged to try to correct the interference by one or more of the following measures:

- Reorient or relocate the receiving antenna.
- Increase the separation between the equipment and receiver.
- Connect the equipment into an outlet on a circuit different from that to which the receiver is connected.
- Consult the dealer or an experienced radio/TV technician for help.

Customer Information

1. This equipment complies with Part 68 of the FCC rules and the requirements adopted by the ACTA. On bottom of this equipment is a label that contains, among other information, a product identifier of ZTEDL05BZXDSL831 . If requested, this number must be provided to the telephone company.
2. If this equipment ADSL CPE causes harm to the telephone network, the telephone company will notify you in advance that temporary discontinuance of service may be required. But if advance notice isn't practical, the telephone company will notify the customer as soon as possible. Also, you will be advised of your right to file a complaint with the FCC if you believe it is necessary.
3. The telephone company may make changes in this facilities, equipment, operations or procedures that could affect the operation of the equipment. If this happens the telephone company will provide advance notice in order for you to make necessary modification to maintain uninterrupted service.
4. If you experience trouble with this equipment, you disconnect it from the network until the problem has been corrected or until you are sure that the equipment is not malfunctioning.
5. Please follow instructions for repairing if any (e.g. battery replacement section); otherwise do not alternate or repair any parts of device except specified.
6. Connection to party line service is subject to state tariffs. Contact the state public utility commission public service commission or corporation commission for information.
7. If the telephone company requests information on what equipment is connected to their lines, inform them of:
 - a) The telephone number that this unit is connected to,
 - b) The ringer equivalence number [REN 0.5B]
 - c) The USOC jack required [RJ11C], and
 - d) The FCC Registration Number : ZTEDL05BZXDSL831Items (b) and (d) are indicated on the label. The ringer equivalence number (REN) is used to determine how many devices can be connected to your telephone line. In most areas, the sum of the RENs of all devices on any one line should not exceed five (5.0). If too many devices are attached, they may not ring properly.

Service Requirements

In the event of equipment malfunction, all repairs should be performed by our Company or an authorized agent. It is the responsibility of users requiring service to report the need for service to our Company or to one of our authorized agents. Service can be facilitated through our office at:

Acadia Solutions, Inc.

130 E. Wilson Bridge Road Suite 320 Worthington, OH 43085.